

719 Vandal Proof

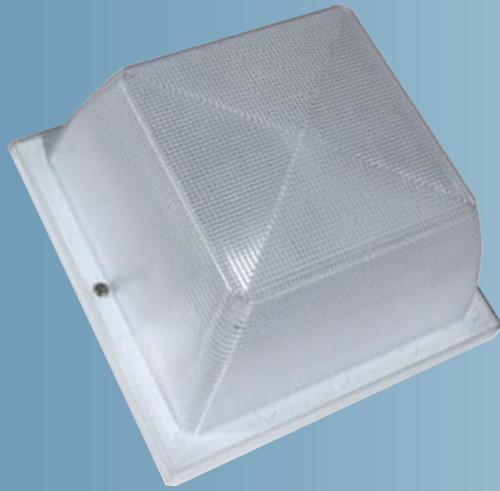

APPLICATIONS

Hallways, Parking Garages,
Stairwells, Common Areas,
Commercial, Institutional

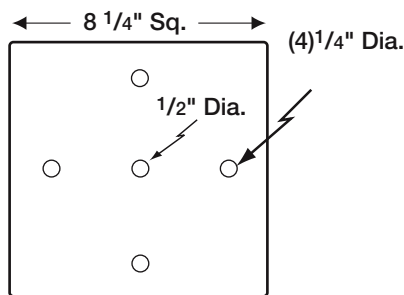
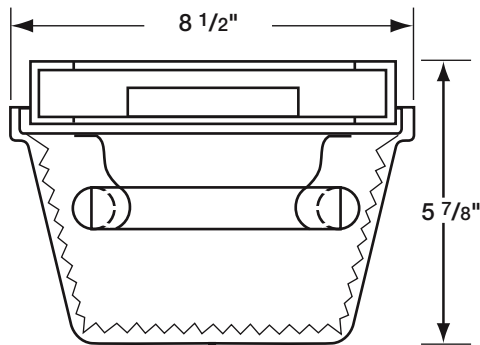

Back View

CONSTRUCTION

Die-formed, cold rolled steel with baked white enamel finish. Crown top with interior and exterior prismatic finish. For use in high abuse areas. Plastic is held in place on two ends with two tamper-proof, stainless steel screws.

MOUNTING

Wall or ceiling mounted. Mounts over electrical junction box. Mounting holes are provided.

FINISH

Phosphate coated, highly reflective, baked white enamel.

OPTICS

Clear prismatic or clear polycarbonate diffuser.

ELECTRICAL

Fixtures and components are all assembled by I.B.E.W. union workers, and are UL and NYC approved.

Knockouts are provided on the back and ends for all types of wiring.

Slide-on or snap-in sockets are provided.

Ballast and sockets are replaceable without removing the fixture from the mounting surface.

Standard ballasts are electronic 120v.

OPTIONS

Check product key or consult factory for available options.

719 - VP - [] - 20 - [] - 120v - [] = Product Number

Series	Description	# of Lamps	Wattage	Size	Voltage	Options
	Vandal Proof		20w		120v	
Vandal Proof						

(Product Number eg.: 400-PV-214-T-277-R)